



CARTER CONTROL SYSTEMS

ISO 9001:2000 CERTIFIED

PRODUCT CATALOG

Effective Date: July 17, 2008

CCS Doc No: FORMGEDFM018, Rev H

CARTER CONTROL SYSTEMS, INC.
7618 Hayward Road
Frederick, MD 21702-3006

TEL: (301) 698-9660

FAX: (301) 695-3851

Website: www.cartercontrols.com

Straight Conveyor – “SC” Series

Straight sections of conveyor are available in various widths and lengths for floor or overhead mounting. Standard features include:

- Throughput: Nominal – 30 trays per minute, Optional – up to 50 trays per minute
- Maximum Mailtray Weight: 70 pounds
- Layout: 30" Zones – (1) Motorized power roller driving (9) idler rollers using O-rings
- Frame: 12 Ga. steel with 2.75" flanges and cross-member supports (CarterRoll™ design)
- Frame Finish: Powder coated per Fed-Std-595 USPS Mail Tray Blue color #25230
- Roller Mounting: TOR 2" below top of frame with spacing on 3" centers
- Expansion: Butt couplings to join adjacent sections
- Power Requirement: 24VDC
- Mail Product Detection: photoelectric sensor/reflector configuration
- I/O Control: Allen Bradley 1799-ZCIOV DeviceNet – master/slave configurations
- Wiring/Controls Containment: Within conveyor side frames with snap-on PVC covers
- Mounting Capabilities: Overhead and floor

Model Configuration

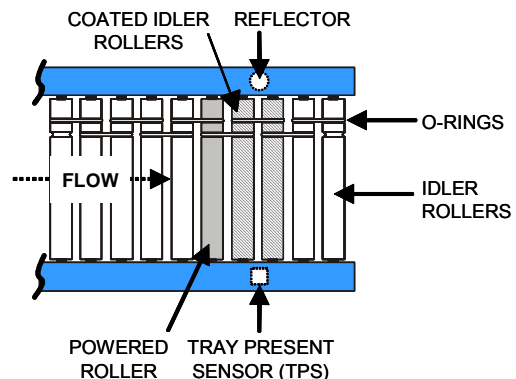
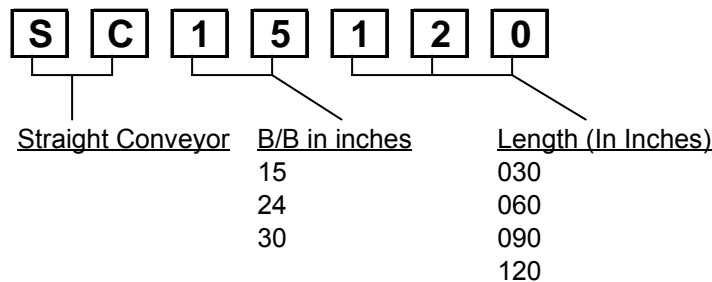

The image above depicts a 30" section (1 standard zone) layout with one motorized roller in the center of the zone and two of the nine slave rollers (to the right of the motorized roller) coated to provide a reduced slippage surface for mail product as it stops in, or moves out of the zone. Frames are assembled with cross-members for structural support. 7/16" hex holes are provided for rollers.

Options

- Standard: 15", 24", and 30" widths
- Standard: 30", 60", 90" and 120" lengths with other custom lengths available
- Controls – I/O Configurations (Master/Slave)

- Inclines: 0-22° for mail product up to 35 pounds, 0-11° for mail product up to 70 pounds
- Declines: 0-22° for mail product up to 35 pounds, 0-11° for mail product up to 70 pounds
- Scanner configurations and mounting support
- Speeds up to 50 trays/minute

CCS conveyors are based on one of three basic configurations in regards to I/O Controls: Master-No Slave, Slave to Master, and Master with Slave. This refers to the I/O Control Module and associated interconnections with adjoining sections that are controlled in common with another section (share the I/O Control Module). The various configurations consist of the following:

1. I/O Control Module and two (2) terminal blocks
2. a terminal block that accepts two (2) plug-in screw-terminal connectors
3. the I/O Control Module, two (2) terminal blocks, and a wire harness assembly with connector. The following image depicts the three versions as single zones

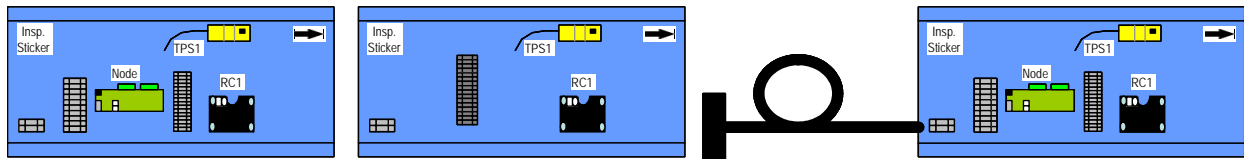

MASTER-NO SLAVE

SLAVE TO MASTER

MASTER WITH SLAVE

All controls and wiring are within the left side (nominally) of the conveyor steel frame, with wiring and cable routing along the lower channel of the frame. Terminal blocks, relays, fused terminal blocks, and slave terminals for I/O Modules are mounted on DIN rail strips attached to the side frame, whereas RC Modules and I/O Control Modules are directly screw-mounted to the side frame.

Customized lengths are available beyond those indicated in the basic model number to suite a variety of system solutions. Modified configurations are used to support various barcode scanning requirements.

Low Sides

Low side options are offered that reduce the conveyor frame along a specific area of the side frame to accommodate mating sections with the conveyor for various configurations. They include: Left-Side, Right-Side, Both Sides, and in single or multiple zones.

Inclines and Declines

Incline and decline conveyors are offered as options, which have design adjustments to compensate for the slope and potential slippage of mail trays. Motorized braking rollers or one-way idler rollers are used, depending on the desired option, with non-slip coatings added to all of the rollers in order to handle these situations. These options include 0-11 degrees and 12-22 degrees angle from the horizontal plan, depending on the size and weight of the mail product.

Dimensions

The end view is shown with snap-on side frame covers in place.

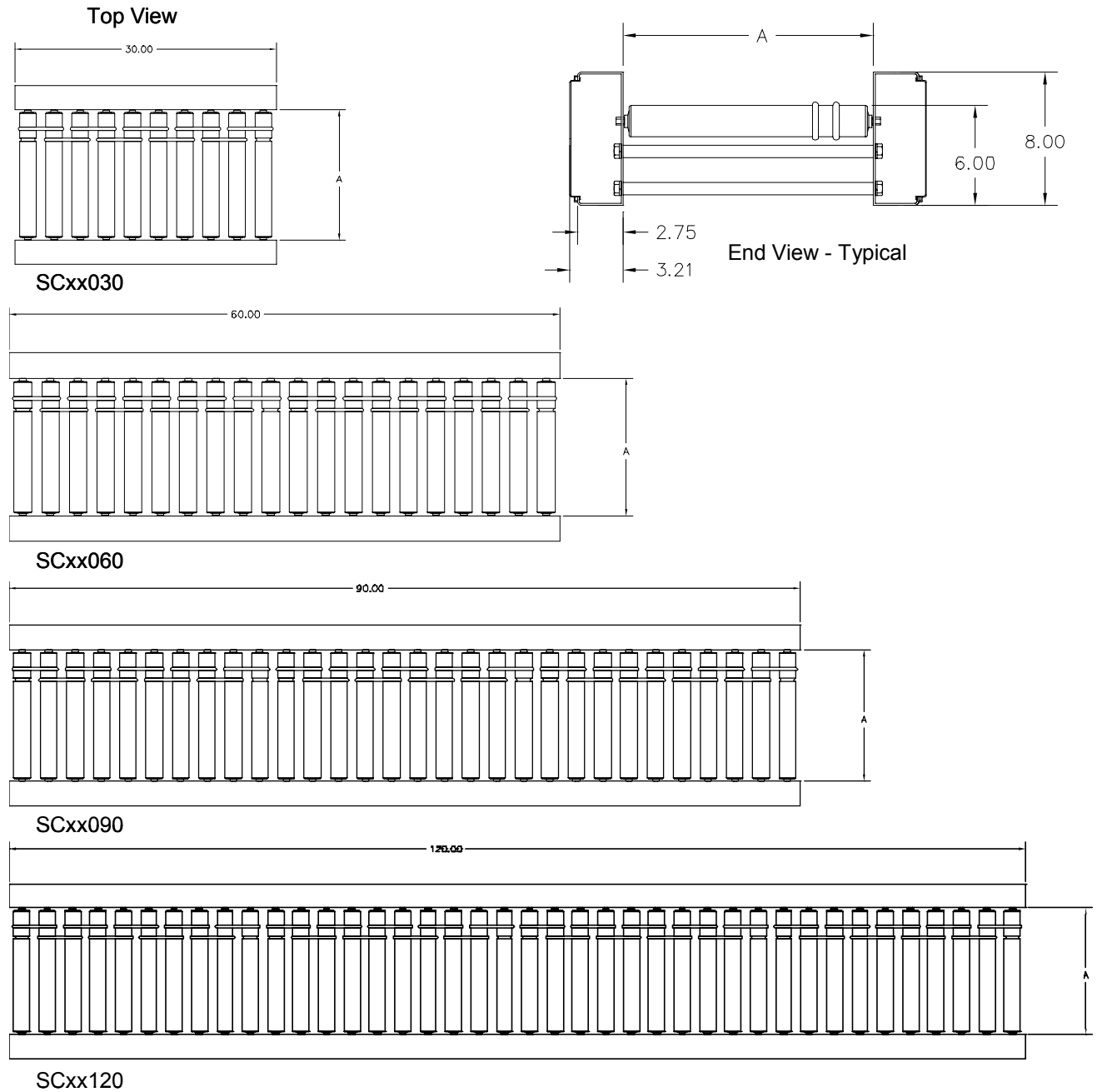

Dimension "A" = xx in Model No.
15", 24", and 30" widths available

Conveyor Curves – “CU” Series

Curved sections of conveyor are available in various widths and lengths for floor or overhead mounting. Standard features include:

- Throughput: Nominal – 30 trays per minute, Optional – up to 50 trays per minute
- Maximum Mailtray Weight: 70 pounds
- Layout: Zones – Motorized power roller driving idler rollers using O-rings (various configurations)
- Frame: 12 Ga. steel with 2.75" flanges and cross-member supports (CarterRoll™ design)
- Frame Finish: Powder coated per Fed-Std-595 USPS Mail Tray Blue color #25230
- Roller Mounting: TOR 2" below top of frame
- Expansion: Butt couplings to join adjacent sections
- Power Requirement: 24VDC
- Mail Product Detection: photoelectric sensor/reflector configuration per zone
- I/O Control: Allen Bradley 1799-ZCIOV DeviceNet – master/slave configurations
- Wiring/Controls Containment: Within conveyor side frames with snap-on PVC covers
- Mounting Capabilities: Overhead and floor

Model Configuration

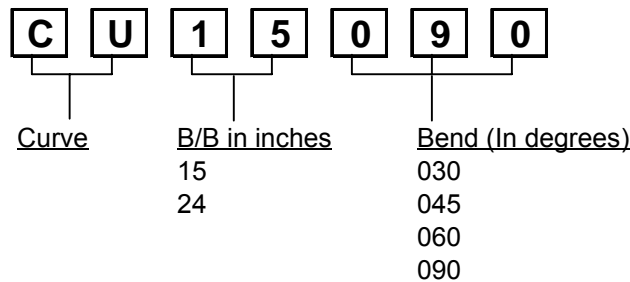

Curved conveyors basically utilize the same construction principals as the straight conveyor sections with the exception that tapered rollers are used throughout and mounted such that the top of rollers are level between the side frames. Also, the number of motorized and idler rollers per zone will vary depending on the size of the curve. A listing of the various configurations follows.

CURVE CW & CCW	ZONES	MOTORIZED ROLLERS/ZONE	IDLER ROLLERS/ZONE	TOTAL O-RINGS
*30°	<1	1	5	5
45°	1	1	8	8
60	1	1	11	11
90°	2	1	8	16

Note: *The length of the 30° curve does not allow it to stand as a zone by itself. Therefore, a 30° curve is bolted to the immediate upstream or downstream conveyor section and coupled with an O-ring to the adjacent roller in the next section as required.

Options

- Clockwise/Counterclockwise
- Standard 15" and 24" widths
- Controls – I/O Configurations (Master/Slave)
- Speeds up to 50 trays/minute

Each curve comes in either a clockwise or counterclockwise rotation of mail product movement, which is dependent on rotational direction of the rollers. The Master-Slave controls philosophy also applies to the curves as in the straight section descriptions.

Dimensions

The following are dimensions for the 15" Back-to-Back Curves. Flanges of the conveyor side frames are 2.75" wide.

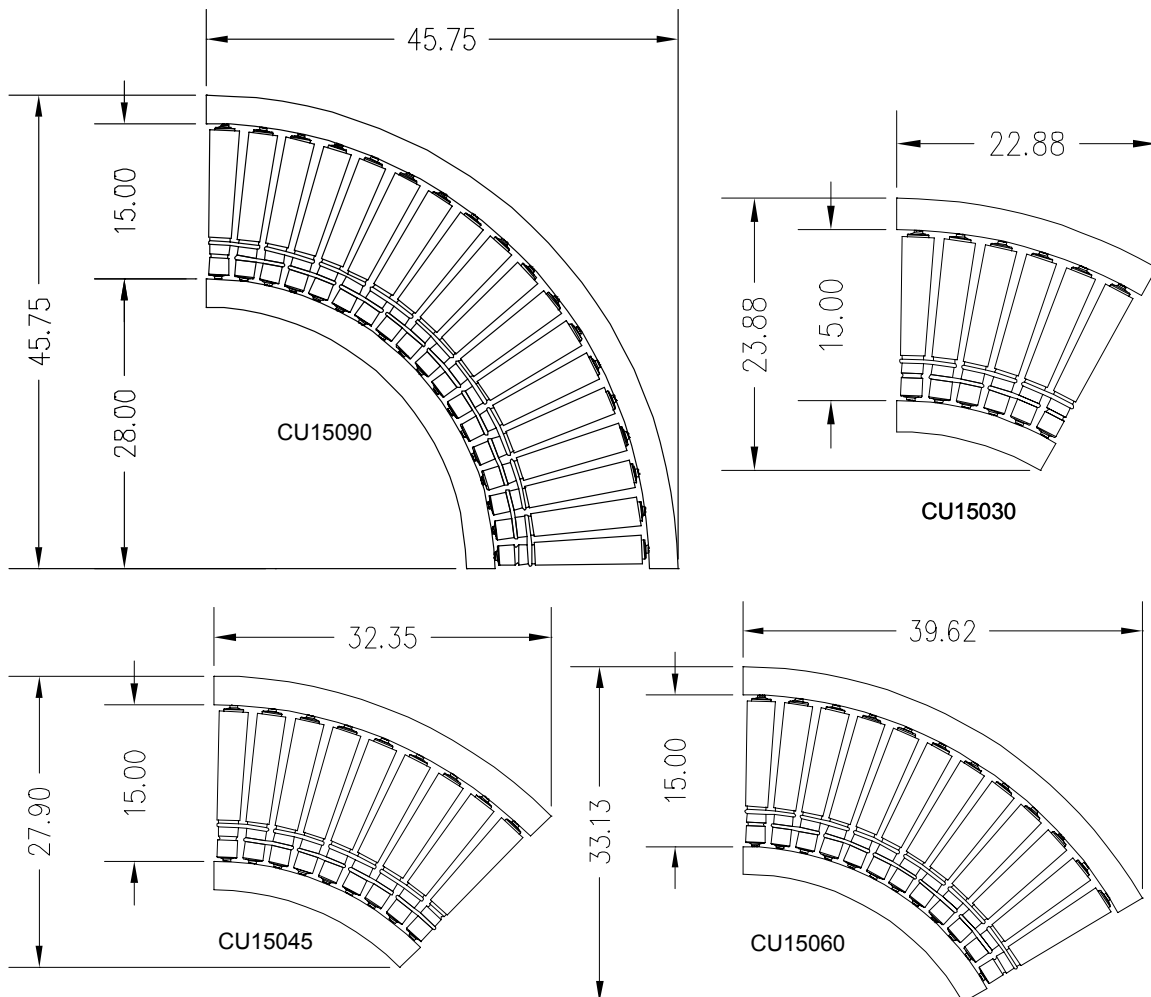

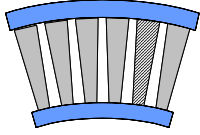
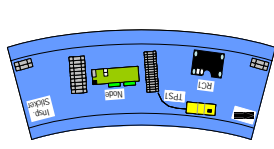

30° CURVE

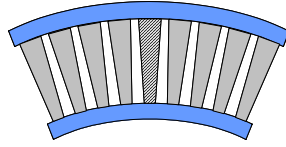
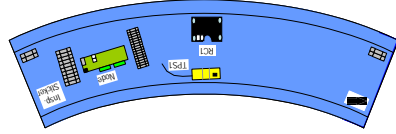

45° CURVE

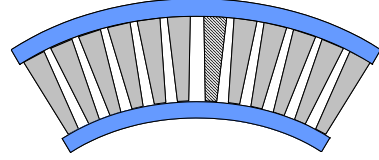
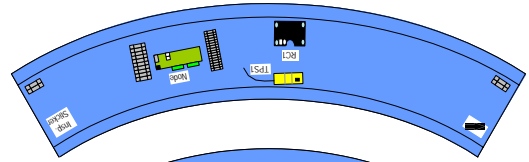

60° CURVE

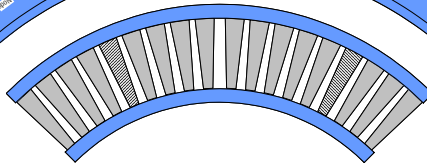
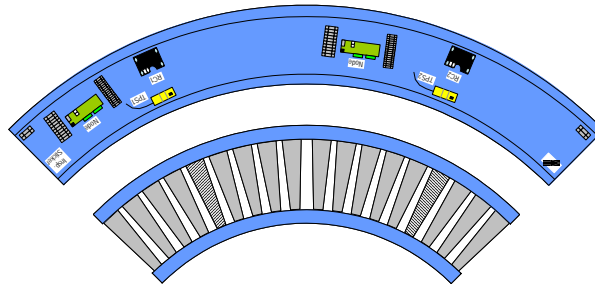

90° CURVE

Merge – “ME” Series

CCS offers a design for a merge section of conveyor, in left and right hand versions, which relates to the side that mail product enters the conveyor line flow. Standard features include:

- Throughput: Nominal – 30 trays per minute, Optional – up to 50 trays per minute
- Maximum Mailtray Weight: 70 pounds
- Merge Angle: 30°
- Layout: Zones – Motorized power roller driving idler rollers using O-rings (various configurations)
- Frame: 12 Ga. steel with 2.75" flanges and cross-member supports
- Frame Finish: Powder coated per Fed-Std-595 USPS Mail Tray Blue color #25230
- Roller Mounting: TOR 2" below top of frame with spacing on 3" centers
- Expansion: Butt couplings to join adjacent sections
- Power Requirement: 24VDC
- Mail Product Detection: Photoelectric sensors
- I/O Control: Allen Bradley 1799-ZCIOV DeviceNet
- Wiring/Controls Containment: Within conveyor frames provided with snap-on covers
- Mounting Capabilities: Overhead and floor

Model Configuration

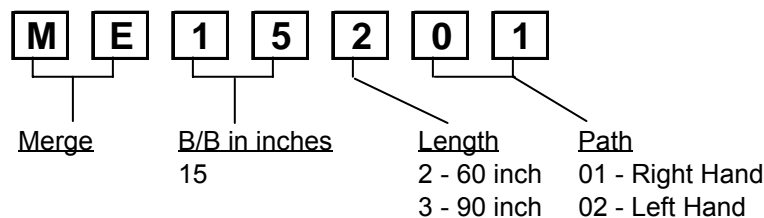

The merge is comprised from the joining of two (2) straight conveyor sections at a 30° angle at the merge point. The side frame on one conveyor is cut down to allow the second a point of entry. The overall length of the merge is either 60" or 90", dependent on the selected model. The only difference is that the 60" version has the last zone (30" portion) removed from the design. A general representation of the flow through a merge follows.

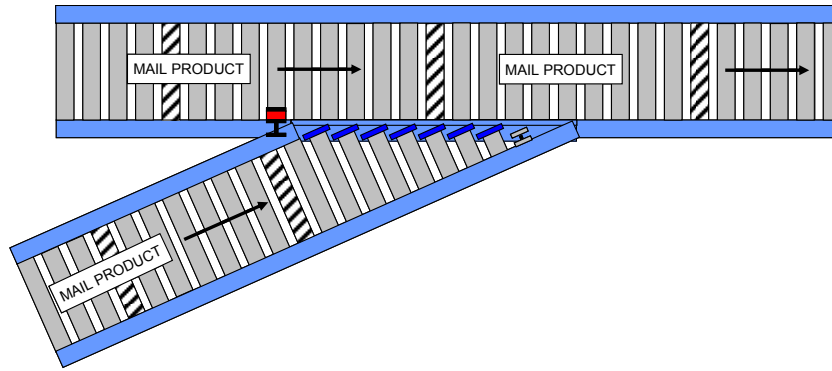

90" RIGHT-HAND MERGE – MAIL PRODUCT FLOW

For the 90" model, the main conveyor section consists of three standard 30" zones and the merging section consists of two zones yielding a total of five (5) zones for the entire conveyor section. The three zones in the main conveyor each consist of one (1) Motorized Power Roller and RC module, nine (9) idler rollers, and nine (9) O-rings, with retro-reflective sensor/reflector pairs for each zone acting as tray present sensors.

For the 60" model, the main conveyor section consists of two standard 30" zones and the merging section consists of two zones yielding a total of four zones for the entire conveyor section. The two zones in the main conveyor section each consists of one (1) Motorized Power Roller and RC module, nine (9) idler rollers, and nine (9) O-rings, with retro-reflective sensor/reflector pairs for each zone acting as tray present sensors.

The two-zone merging section for the 60" and 90" models consists of two (2) Motorized Power Rollers and RC modules, one (1) retro-reflective sensor/reflector pair, 17 idler rollers (some coated and some shorter), 16 O-rings, and one skatewheel roller assembly at the shortest roller position. Beaded value-guide is included (90" version only) to reduce mail product rubbing against the inside of the conveyor side frame just past the merge point.

A JAM sensor is included to detect jams at the merge point and a JAM lantern is provided to visually indicate this condition. When the sensor has shown mail product more than a specified amount of time, the merge is halted and the JAM lantern is activated.

Options

- Left-Hand or Right-Hand
- 60" or 90" length
- Controls – I/O Configurations (Master/Slave)
- Other conveyor widths
- Speeds up to 50 trays/minute

Dimensions

The Left-Hand and Right-Hand Merges are mirrored images.

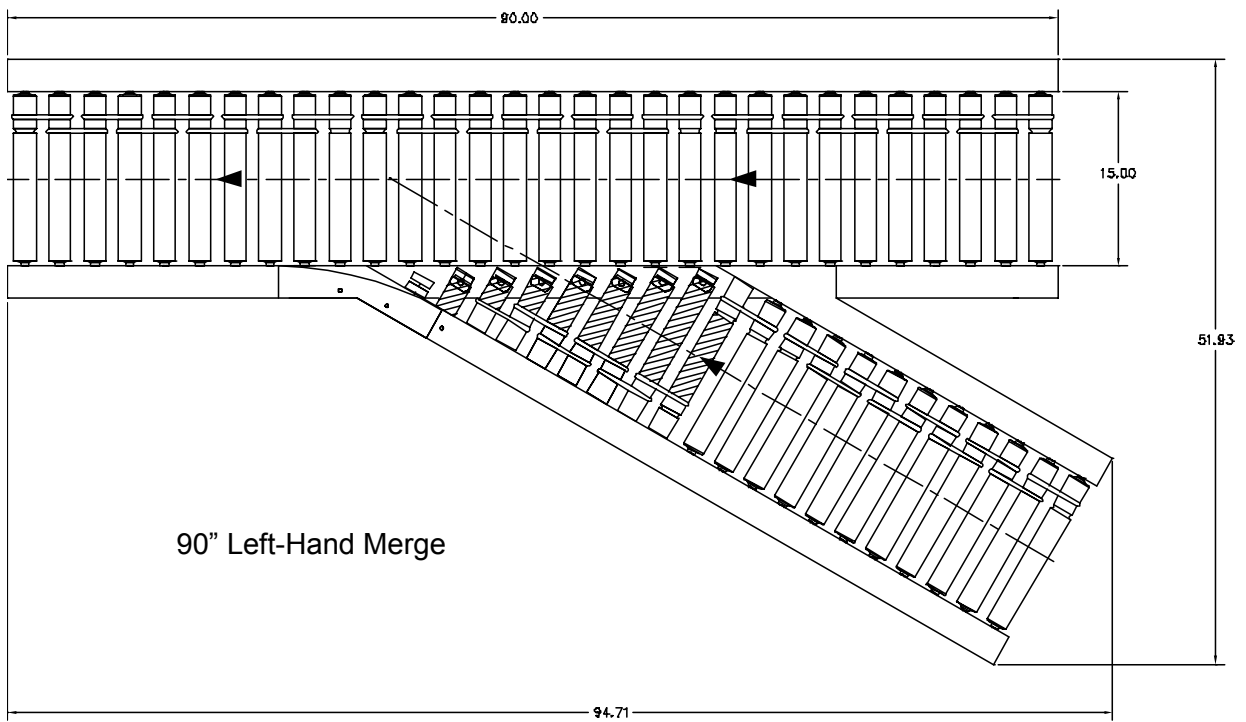
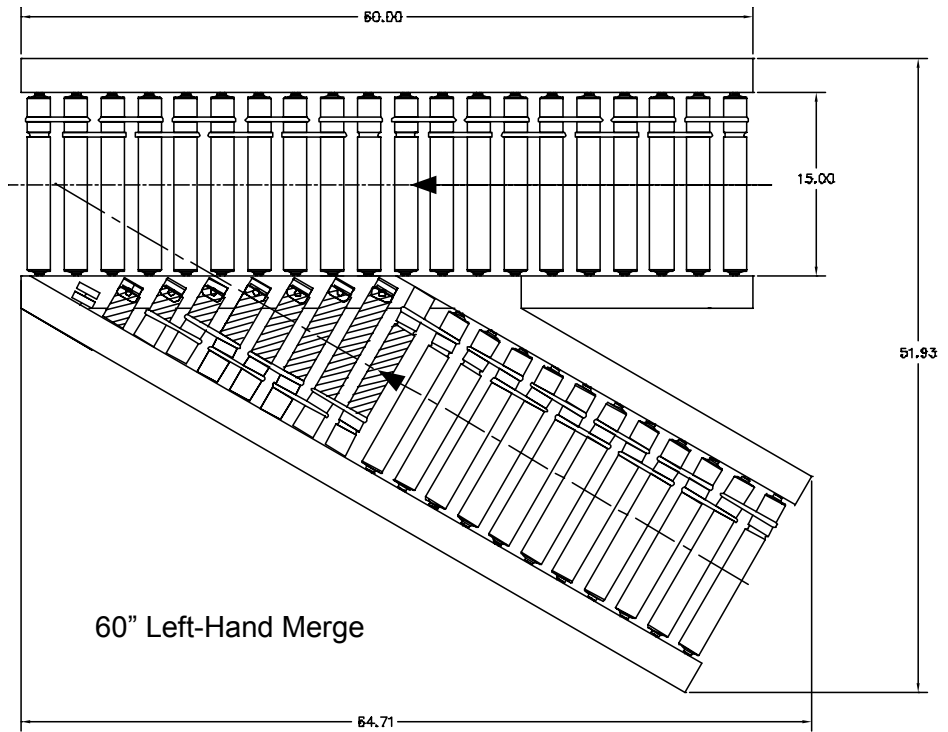

Intersection – “IN” Series

A standard intersection conveyor section is comprised of a single 30" Back-to-Back (BB) × 15" long zone positioned at a right angle to a 15" BB × 36" long zone. A variation to the basic intersection is one that will physically interface with Automated Flats Sortation Machines (AFSMs). An “AFSM” intersection conveyor section is comprised of a single 18" Back-to-Back (BB) × 15" long zone positioned at a right angle to a 15" BB × 24" long zone. Intersections are available in either right or left-hand versions. These sections are used in applications where mail product traveling lengthwise across (sideways) the conveyor needs to be merged into a main line handling mail product lengthwise along the conveyor. Standard features include:

- Throughput: 30 trays per minute
- Maximum Mailtray Weight: 70 pounds
- Transition: From 30" to 15" (standard) or 18" to 15" (AFSM) Back-to-Back conveyance path with left or right-hand versions
- Layout: Two (2) perpendicular Zones – Motorized power roller driving idler rollers using O-rings
- Frame: 12 Ga. steel with 2.75" flanges and cross-member supports
- Frame Finish: Powder coated per Fed-Std-595 USPS Mail Tray Blue color #25230
- Roller Mounting: TOR 2" below top of frame with spacing on 3" centers
- Attachment: Butt couplings to join adjacent sections
- Power Requirement: 24VDC
- Mail Product Detection: Photoelectric sensors
- I/O Control: Allen Bradley 1799-ZCIOV DeviceNet
- Wiring/Controls Containment: Within conveyor frames provided with snap-on covers
- Mounting Capabilities: Overhead and floor

Model Configuration

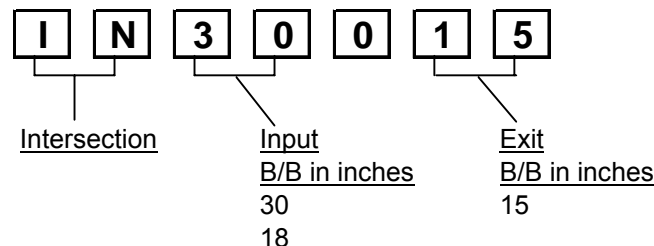

Standard Intersection – The 30" B-B × 15" long zone is comprised of a single motorized roller, Four (4) coated idler rollers, four (4) O-rings, and one retro-reflective sensor/reflector pair. The 15" B-B × 36" long zone is comprised of a single motorized roller, 11 idler rollers, 11 O-rings, and two (2)

retro-reflective sensors/reflector pairs. Frames are fabricated to provide a smooth transition onto the main line.

AFSM Intersection – The 18" B-B × 15" long zone is comprised of a single motorized roller, four (4) coated idler rollers, four (4) O-rings, and one retro-reflective sensor/reflector pair. The 15" B-B × 24" long zone is comprised of a single motorized roller, seven (7) idler rollers, seven (7) O-rings, and two (2) retro-reflective sensors/reflector pairs. Frames are fabricated to provide a smooth transition onto the main line.

A general representation of the standard intersection follows.

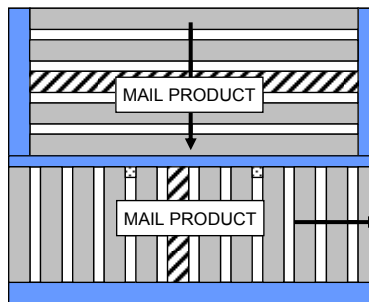

LEFT SIDE INTERSECTION – MAIL PRODUCT FLOW

The basic idea of an intersection is to apply sufficient drive to move the mail product across the rollers mounted in the receiving conveyor portion. The use of a high torque motorized roller in conjunction with coated slave rollers at the intersection point provides the driving force. There is no coating applied to the rollers in the receiving conveyor portion in the area of the intersection point.

Options

- Left-Hand or Right-Hand version

Standard Dimensions

Left-Hand and Right-Hand Intersections are mirrored.

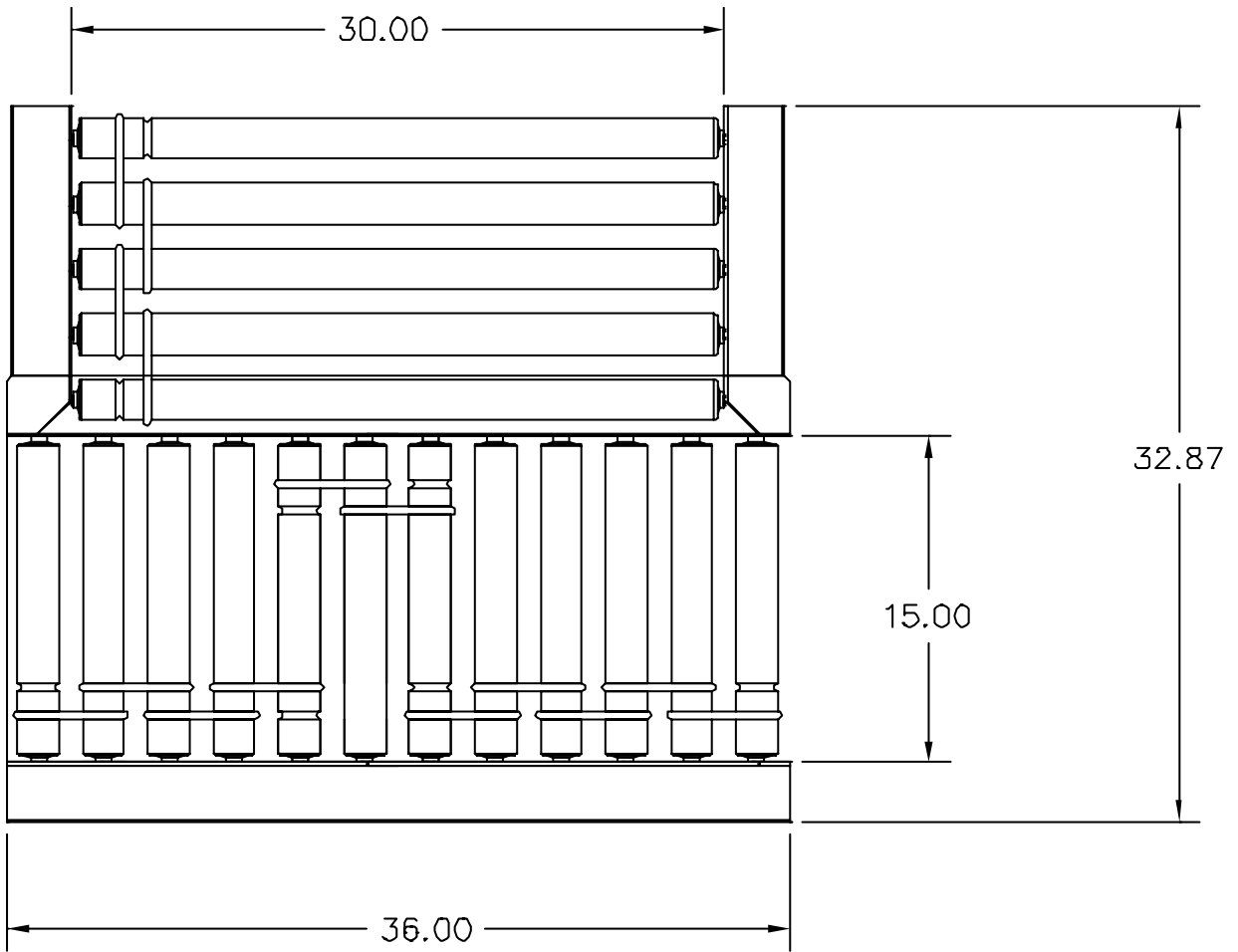

AFSM Dimensions

Left-Side and Right-Side Intersections are mirrored.

