



CARTER CONTROL SYSTEMS

ISO 9001:2000 CERTIFIED

PRODUCT CATALOG

Effective Date: July 17, 2008

CCS Doc No: FORMGEDFM018, Rev H

CARTER CONTROL SYSTEMS, INC.
7618 Hayward Road
Frederick, MD 21702-3006

TEL: (301) 698-9660

FAX: (301) 695-3851

Website: www.cartercontrols.com

Powered Spiral Conveyor™ – “PRSU” & “PRSD” Series

Carter Control Systems’ Powered Spiral Conveyor™ is a patented powered roller conveyor assembly that provides a means to move mail product from the ground level to an elevated level (Up Spiral model) or from an elevated level to the ground level (Down Spiral model), as predefined by specific site requirements. The diameter of the Spiral comes in three standard sizes 63” small, 73” medium, and 98” large diameters; optional 100/120” large diameters. Standard features include:

- Throughput: 30 trays per minute, Optional – Up to 50 trays/minute
- Zero-Pressure Accumulation
- Maximum Mailtray Weight: 70 pounds
- Mail Product Rotation: Clockwise or Counterclockwise
- Layout: Zones (modified) – Motorized power roller driving idler rollers using O-rings
- Conveyance Path: 63” version = 16” width, 73” and 98” versions = 15” width
- Curves: 10 Ga. Steel, Outside = 10” tall (5” above roller), Inside = 8” tall (2” above roller)
- Frame Finish: Powder coated per Fed-Std-595 USPS Mail Tray Blue color #25230
- Mail Product Detection: Photoelectric sensors
- Wiring/Controls Containment: Through spiral curves and along upright supports
- Mounting Capabilities: Floor (or mezzanine)
- Main Control Panel (MCP) for DC power sources and controls
- I/O Control: Allen Bradley 1799-ZCIOV DeviceNet
- Power Requirement: 480 or 208VAC, 3-Phase

Model Configuration

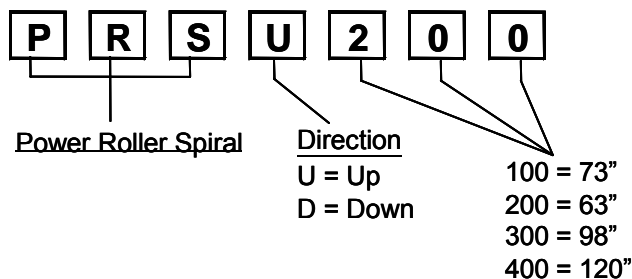

The CCS Powered Spiral Conveyor™ provides a small footprint solution for vertical movement of trays and/or accumulation storage as an operational buffer. Mail product may enter and exit the

spiral at any 90° arc and move through the conveyor in either a Clockwise (CW) or Counter-Clockwise (CCW) direction of rotation (in a cork-screw like manner).

Four (4) different infeed/outfeed configurations are available for each of the CW, CCW, Up, and Down variations as shown in the following image. This results in 16 different overall configurations possible for the spiral.

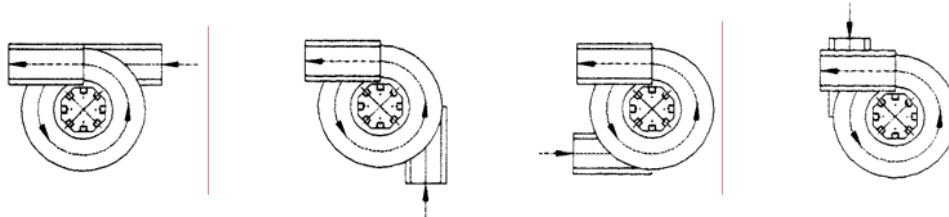

CCS has developed a configuration sheet with instructions for customer use in providing CCS information needed to define their layout and develop pricing. *This sheet and instructions are provided to the customer to assist in the ordering process.* The Powered Spiral Conveyor™ consists of coated motorized and slave rollers. Height is determined by top of roller requirements for entry and discharge points on the spiral.

The Spiral utilizes brushless motorized drive rollers located in each zone, driving the slave rollers, which are interconnected (daisy chained) via ‘O’ rings. The Spiral is able to control the upward/downward direction as well as accumulate and hold the trays in position. The number of motorized rollers and the associated slave driven idler rollers that make up a “zone” within the Spiral is dependent on the diameter of the Spiral and whether the Spiral is an Up or Down model. Additional motorized drive rollers are utilized, as needed, to assure the consistent movement, control and orientation of the heaviest required tray. The motorized rollers operate only as required to transport a mail tray. When there is a backup on the downstream conveyor (blocked sensor, i.e., full, jam, etc.), trays accumulate within the Spiral until the downstream condition is resolved. Each motorized roller stops when a tray is positioned on it and functions as a brake to eliminate pressure between trays when the Spiral is in the accumulating mode.

The number of mail trays that can be stored in each 360° of rotation and the associated vertical space consumed is listed in the following table:

SPIRAL OUTSIDE DIAMETER (INCHES)	MAIL TRAYS PER 360° OF ARC (NO OF TRAYS)	AREA OF VERTICAL SPACE BETWEEN LEVELS (INCHES)
63"	4	23.0"
73"	6	25.5"
98"	8	23.0"

Motion of product through the Spiral can be either clockwise or counterclockwise depending on the input and output directions, with inputs and outputs available at any 90° of rotation. Either powered braking rollers or one-way clutch idler rollers are used in the design dependent on the required downward or upward movement of trays, respectively.

The spiral consists of multiples of 180° curved powered conveyors and/or 90° curved sections, depending on the diameter, with the total number of spiral curves dependent on the actual height. Each section consists of multiple zones using tapered motorized power and idler rollers. Quantity and configurations are dependent of the final design selected.

The Spiral unit consists of:

- Steel frame structure with:
 - Top and bottom plates
 - 4 or 8 vertical uprights (outfitted with powered roller controls at local level)
 - Conveyor support arms
- Multiple 180° motorized conveyor curves with sensors and rollers for a 1/2 turn (180°) of the Spiral for the 63" and 73" versions or multiple 90° motorized conveyor curves for the 98" version
- Optional 90° powered conveyor curve for a 1/4 turn (90°) of the Spiral for the 63" and 73" versions only
- Spiral Main Control Panel (MCP) for interconnection with facility AC 3-Phase power, 24VDC power supplies, upper level controls and protection circuitry, and interconnection with Input/Output (I/O) devices located throughout the Spiral as well as interlocks with feed and takeaway conveyors*

Note: **The functions of the Spiral Main Power Panel (MPP) and associated Spiral Control Panel are normally combined within a single panel mounted at the base of the Spiral. This combined panel may be supplied as a separate free-standing panel(s). Where the single combined panel contains the Spiral AC power and 24VDC power supplies, it is denoted as the "Spiral MCP." See illustration below.*

The spiral requires either 208 or 480VAC 3-phase power as a primary source and its controls are based on the DeviceNet configuration, using the Allen Bradley 1799-CZIOV I/O Control Modules. These controls interact with the motorized roller RC Modules and sensors within each zone to provide the overall zero-pressure accumulating solution.

Spirals include the control panel(s) provided in one of four possible configurations depending on the spiral elevation and number of zones requirements. These four possibilities are represented as follows:

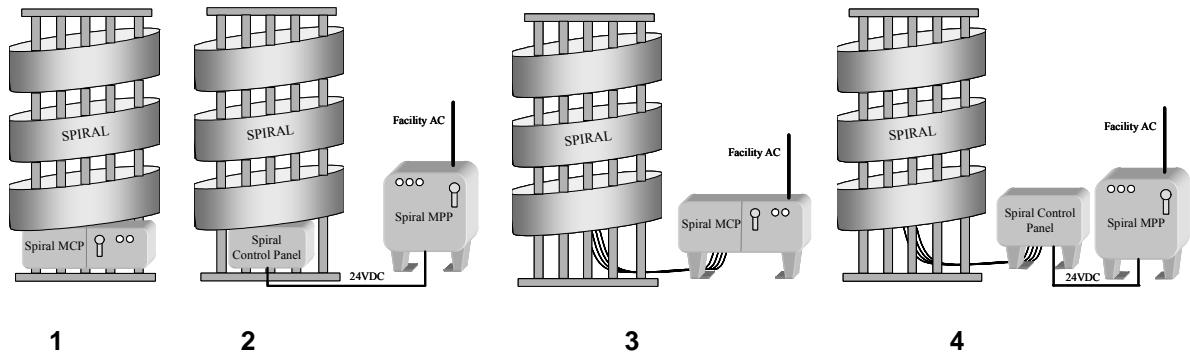



1. Standard: Combined MCP-Spiral Control Panel in a single enclosure (mounted under the Spiral).
2. Spiral Control Panel (mounted under the Spiral) with separate free standing MPP mounted on support feet. (taller spirals requiring additional 24VDC power supplies).
3. Free standing combined Spiral Control Panel and MCP in a single enclosure mounted on support feet. (lower level of spiral is too close to the floor).
4. Free standing Spiral Control Panel and separate MPP, both mounted on support feet. (lower level of the spiral is too close to the floor and the unit is taller requiring additional 24VDC power supplies).

Fully assembled spirals are delivered directly to the customer job-site on a reusable CCS designed carrier transporter. This carrier is returned to CCS once of the spiral has been removed and installed.

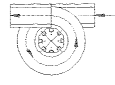
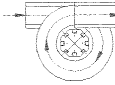
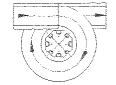
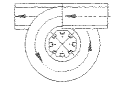
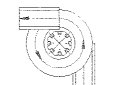
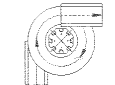
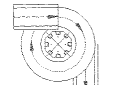
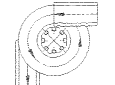
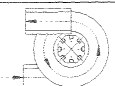

**A copy of the configuration sheet used to define customer requirements for the Powered Spiral Conveyor™ is provided on the following pages.*

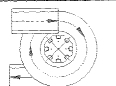
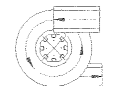
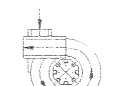
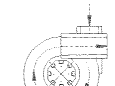
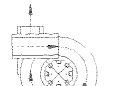
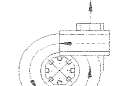
POWERED SPIRAL CONVEYOR™ - REQUEST / ORDER FORM <small>U.S. Patent # 5,901,827, #6,199,677 B1, #6,298,971 B2, #6,398,014B2, Additional Patents Pending.</small>			
 CARTER CONTROL SYSTEMS, INC. <small>ISO 9001:2000, CERTIFIED</small>	Carter Control Systems, Inc. 7618 Hayward Road Frederick, Maryland 21702-3006 Tel: 301-698-9660, Fax: 301-695-3851 Email: Info@cartercontrols.com Web: www.cartercontrols.com	Date: Delivery Date: CCS Project No: Contact Name: Phone:	
Customer / Company Name:		Customer Contract / Purchase Order No:	
Billing Address:		Delivery Site Address:	
Product/Material Handled: <input type="checkbox"/> Trays <input type="checkbox"/> Tubs <input type="checkbox"/> Mixed <input type="checkbox"/> Other:		Power Source: <input type="checkbox"/> 208V, 3PH <input type="checkbox"/> 480V, 3PH	
Products Per Minute:		Outfeed Height:	
DIAMETER: <input type="checkbox"/> 63" <input type="checkbox"/> 73" <input type="checkbox"/> 98"		Infeed Height:	
STANDARD SPIRAL CONFIGURATIONS <small>Select desired Infeed / Outfeed configuration below.</small>			
UP Spiral - COUNTER CLOCKWISE	UP Spiral - CLOCKWISE	DOWN Spiral - CLOCKWISE	DOWN Spiral - COUNTER CLOCKWISE
<input type="checkbox"/> 	<input type="checkbox"/> 	<input type="checkbox"/> 	<input type="checkbox"/> 
<input type="checkbox"/> 	<input type="checkbox"/> 	<input type="checkbox"/> 	<input type="checkbox"/> 
<input type="checkbox"/> 	<input type="checkbox"/> 	<input type="checkbox"/> 	<input type="checkbox"/> 
<input type="checkbox"/> 	<input type="checkbox"/> 	<input type="checkbox"/> 	<input type="checkbox"/> 
CUSTOM ORDER			
SPECIAL REQUEST:		Length: Min:	Max:
		Width: Min:	Max:
		Height: Min:	Max:
		Weight: Min:	Max:

Notes - 1) - Weight of Spiral will be estimated with order confirmation. 2) - Use one Order Form per Spiral.

Form No: FORMEGDFM007 - Rev. E

1

SHIPPING INFORMATION

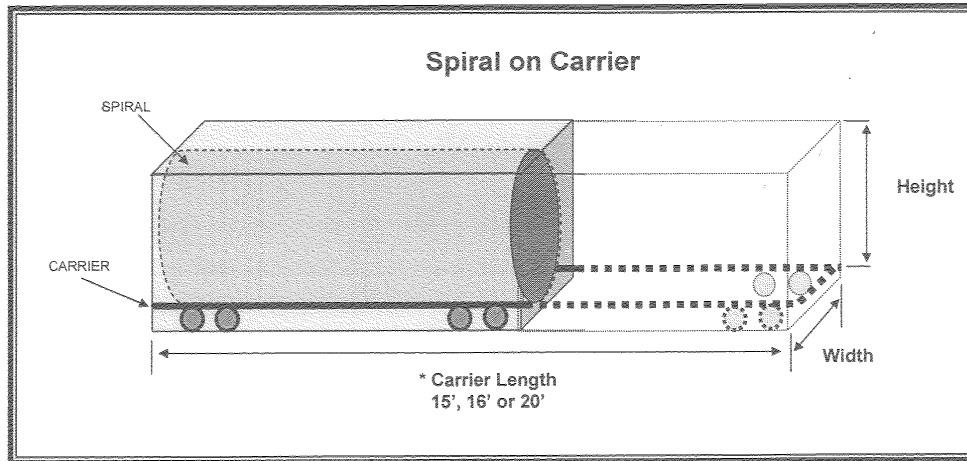

Shipping Cube

Spiral	Width	Height	*Length
63"	5'5"	6'6"	*
73"	6'3"	6'6"	*
98"	8'2"	8'6"	*

*** NOTE**

Spiral Carrier Length: Standard Spiral Carrier lengths are 15, 16 and 20 feet. If facility space requires specific length, indicate as a "Special Request".

***** **NOTICE** *****

It is customer's responsibility to confirm that facility doors and openings are adequate to accommodate the spiral and carrier.

HOW TO USE THIS FORM – This form has been designed to be used two ways; hand written or electronically in MS Word. To use electronically, open the form in MS Word, click on the grayed text fields and type info. To select and unselect check boxes, simply click on the box.

Notes - 1) - Weight of Spiral will be estimated with order confirmation. 2) – Use one Order Form per Spiral.